

DWG #: D00127 REV: A

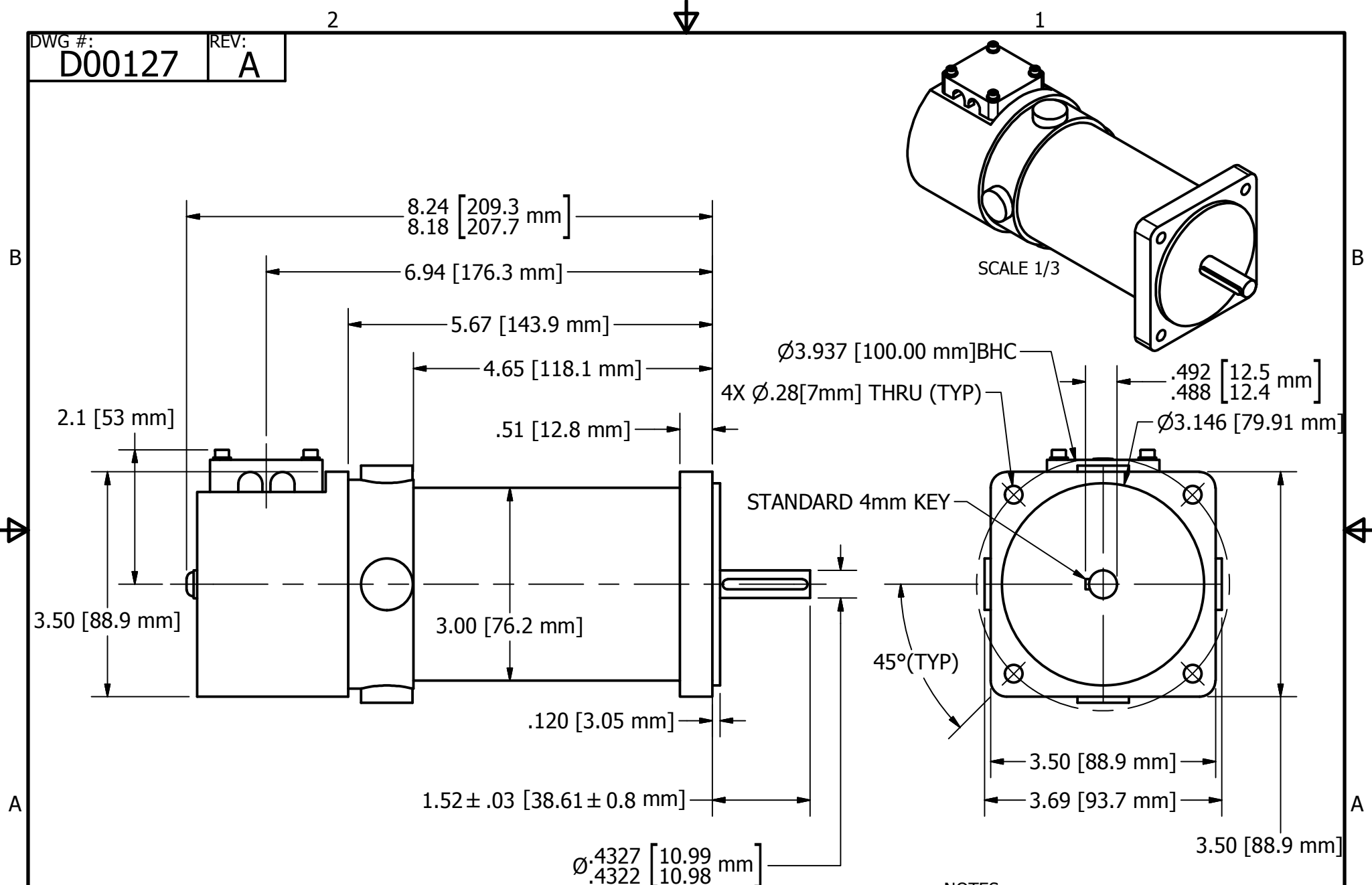

DATE  
DRAWN: 8.31.13

NOTES:  
1. PART #7397  
COPYRIGHT CENTROID CORP.

**CENTROID**  
 T:(814)353-9290 F:(814)353-9265  
 www.CENTROIDCNC.com

TOLERANCES Xmm ± 0.5 0' ± 30'  
 UNLESS XXmm ± .25 0.0' ± 3'  
 OTHERWISE XXXmm ± .125  
 SPECIFIED:

TITLE: 16 IN-LB DC SERVO MOTOR	DRAWN: SZP
FINISH: NA	APPROVED:
MATERIAL: NA	DWG #: D00127
SCALE: 1/2	REV: A